

A602
1/2"~2" (DN15~50)



Forged Steel Gate Valve

The forged steel gate valve is a small forging shut-off valve which is widely used in all types of thermal power plants. This type valve is with solid wedge, welding bonnet, bolt bonnet and pressure seal type as well as full port and reduced port. Valve sizes from 1/2" to 2" matching pressure from class 150 to class 2500. Valve connection can be NPT, BW, SW and RF. Valve materials cover carbon steel, such as A 105, LF2; stainless steel, such as F304, F316; alloy steel, such as F11, F22, F91. Valves are operated by manual, motor actuator and pneumatic actuator.

- Two inch and smaller valves are available with threaded or socket weld ends as standard.
- Made from one piece, die-forged bodies.
- All internal surfaces are accurately machined to provide maximum performance.
- Renewable seat rings are made from hardened stainless steel, faced with Stellite.
- The wedge is forged, hardened, ground, and lapped to ensure leak free sealing.
- Fully guided wedge, precision machined body channels, for accurate, repeatable seating alignment.
- Graphite packing, complete with braided graphite filament yarn anti-extrusion rings, is standard.
- Standard body and bonnet materials are carbon steel (ASME SA105), alloy steel (ASME SA182 Gr. F11) and stainless steel (ASME SA182 Gr. F316) Trim for steel valves is 13% chrome stainless steel. 316 stainless steel valves have 316 trim.
- Code compliance with ASME B16.34 and the ASME boiler and pressure vessel code, Section I.

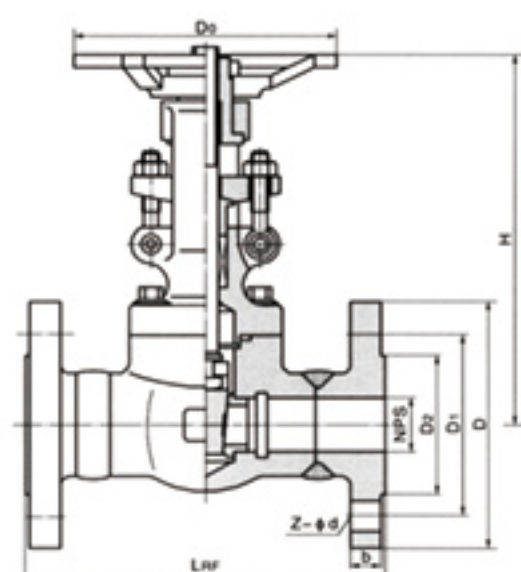

Specifications

Valve Size	1/4"~2", DN10-DN50
Pressure Class	150LB-2500LB, PN16-PN420
Materials	Carbon Steel: A105, LF2, Stainless Steel: F304, F304L, F316, F316L, Duplex: F51, F55, Alloy: F1, F5, F5A, F9, F11, F22;
Design and Manufacturing Standards	API602, ASME 16.34, BS 5352, BS 6364;
Flange Dimension Standards	SW Socket welding ends according to ASME B16.11, BW butt end by ASME B16.25, NPT threaded connectors according to ASME B1.20.1
Pressure Test Standards	API 598
Quality/Product Certifications	ISO9001, ISO14001, ISO18001;
Fugitive Emissions	ISO 15848-1, API 622;
NACE	NACE MR 0103 NACE MR 0175;
Valve operator options	Handwheel, Worm Gear, Electric actuator, Pneumatic actuator, Hydraulic Actuator;
Shutoff Class	API 598 (Zero Leakage), API 6D
Bore	Full Bore, Reduced Bore
Process Connection Types	SW, NPT, BW, RF, RTJ

Main External and Connection Dimension

Nominal Diameter DN(mm)	Main External and Connecting Dimensions								WT(kg)
	L	d	S	L ₁	T	L ₂	H	D ₀	
Z41H-16C Z41H-25 Z41H-40 Z11H-16C Z11H-25 Z11H-40 Z61H-16C Z61H-25 Z61H-40									
15	90	13	22.5	10	1/2	15	151	118	6.9
20	100	18	28.5	11	3/4	17	182	130	9.8
25	120	23	34.5	12	1	19	197	150	13.5
32	120	28	43	14	1 ¼	21	201	166	19.5
40	135	36	49	15	1 ½	21	227	180	28.5
50	155	45	61	16	2	25	253	180	30.3
Z41H-64 Z11H-64 Z61H-64									
15	90	16	22.5	10	1/2	15	151	118	7.7
20	100	18	28.5	11	3/4	17	182	130	11.3
25	120	23	34.5	12	1	19	197	150	16.8
32	130	28	43	14	1 ¼	21	212	180	21.2
40	150	36	49	15	1 ½	21	231	180	32.6
50	155	45	61	16	2	25	253	180	35

Nominal Diameter DN(mm)	Main External and Connecting Dimensions								WT(kg)
	L	d	S	L ₁	T	L ₂	H	D ₀	
Z41Y-100 Z11Y-100 Z61Y-100									
15	90	13	22.5	10	1/2	15	151	118	7.8
20	100	18	28.5	11	3/4	17	182	130	12.5
25	120	23	34.5	12	1	19	197	150	17.5
32	130	28	43	14	1 ¼	21	212	180	23.5
40	150	36	49	15	1 ½	21	131	180	38.5
50	155	45	61	16	2	25	253	180	42.2
Z41Y-160 Z11Y-160 Z61Y-160									
15	90	13	22.5	10	1/2	15	151	118	8.0
20	100	18	28.5	11	3/4	17	182	130	13.6
25	120	23	34.5	12	1	19	197	150	19.4
32	130	28	43	14	1 ¼	21	212	180	25.1
40	150	36	49	15	1 ½	21	231	180	41.6
50	155	45	61	16	2	25	253	180	49.0

AEN.TECH CONTACT

No. 309, Anqian Road, High-tech Zone, Anshan, Liaoning, China

E-mail: liuchangsong9688@gmail.com, ceo@asaicn.com

TEL No: +86 04122616600

www.aen-valve.com

All statements, technical information, and recommendations in this brochure are only for general use. For your specific requirements and material selection, please consult with representatives or sales of AEN.TECH. The right to change or modify the product design or product itself without prior notice is reserved.